



SILVER SPORT Transmissions



FTE Style Bearing

GM C10 1963-66

HYDRAULIC MOUNT and CLUTCH PEDAL INSTALLATION INSTRUCTIONS

The material herein is the intellectual property of Silver Sport Transmissions ("SST") and is to be used by SST customers or their authorized installers for the sole purpose of installing SST-supplied transmissions and related parts. Under no circumstances shall the manual or any portion thereof be copied, duplicated, distributed or incorporated in any written or printed document without the express written approval of Silver Sport Transmissions.

SYSTEM DESCRIPTION:

These instructions cover ONLY the installation of hydraulic master cylinder assembly and mount for the GM C10 1963-66 for both the factory manual and factory automatic applications.

Refer to MAG-00402 (FTE style) or MAG-00403 (RAM style) HYDRAULIC KIT INSTRUCTIONS FOR GM TKO, T56, MAGNUM, AND LGT700 for complete instructions on installation of the hydraulic concentric slave cylinder (CSC) and hydraulic release system operation.

KIT CONTENTS

Please confirm that all parts have been received. The parts contained in your Master Cylinder kit will include:

- hydraulic mount, gasket, and hardware
- rod end with extension, attachment hardware
- master cylinder

Not pictured:

- braided steel pressure hose with bleeder
- bellhousing boot



If the hydraulic kit was ordered at the same time as the transmission, then your CSC will already be mounted on the front of the transmission.

Typical Master Cylinder Assembly:

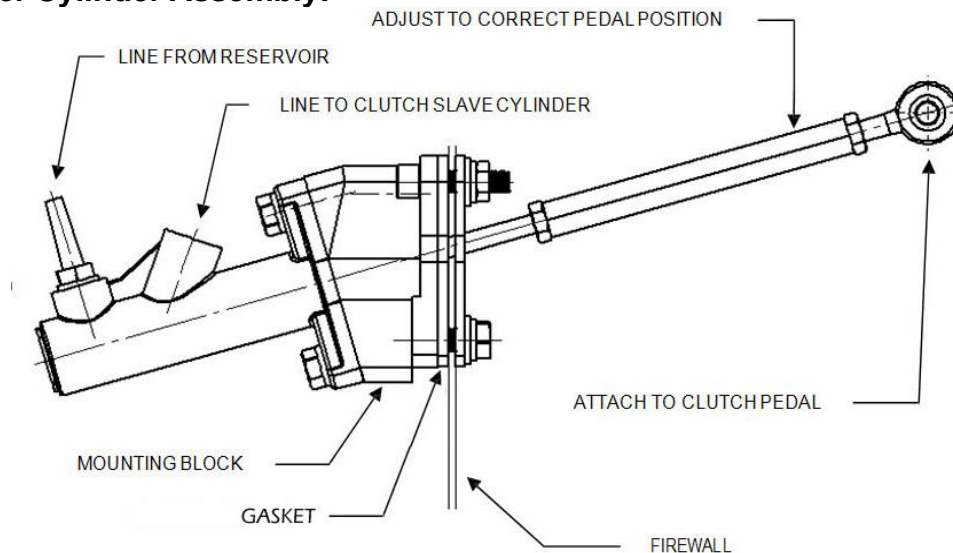

DISASSEMBLY

Remove original clutch linkage, transmission and bellhousing components:

- Fork push rod, clutch pedal push rod assembly
- Z-bar retaining clip, Z-bar, ball stud and bracket assembly
- Fork boot
- Transmission and bellhousing
- Throw-out bearing, clutch fork and fork pivot
- Clutch pedal (must be modified for SST hydraulic system)

Master Cylinder Mounting

1. Locate the contour on the firewall on the driver's side of the master cylinder.



Figure 3.1
Inside cab



Figure 3.2
Engine
compartment

2. Line up the template with the contour on the firewall and mark location of the (2) mount block mounting holes and the center hole. Carefully drill (2) 0.34" dia holes thru the firewall. Cut 1-1/4" dia center hole thru firewall and deburr.

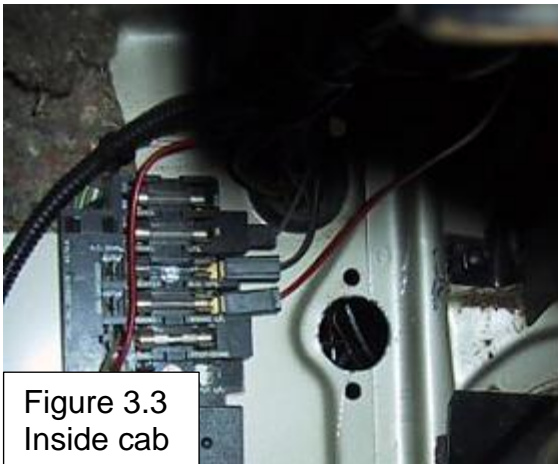

Figure 3.3
Inside cab

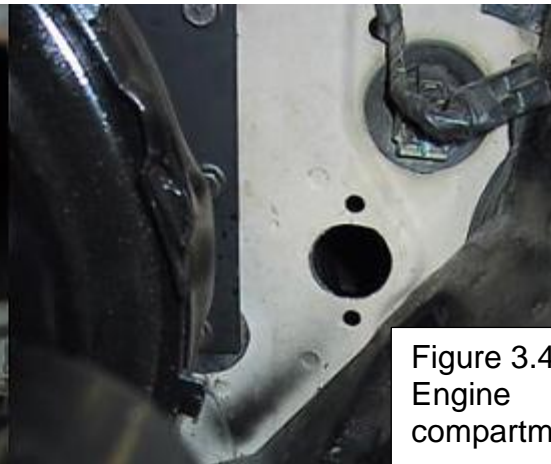

Figure 3.4
Engine
compartment

3. Assemble gasket to master cylinder, then insert the master cylinder to the firewall with the (2) bolts protruding into the cabin area.
4. Install stiffener plate, flat washers, lock washers, and nuts. Align master cylinder, then tighten nuts to 15 ft.-lbs.
5. Assemble the 90° end of the braided steel line to master cylinder port closest to firewall.
6. The reservoir rubber hose barb fitting should already be installed in master cylinder at port located furthest from firewall.

Use caution not to over tighten and break fittings.

PEDAL ATTACHMENT

NOTE: If you are changing from a three (3) finger style pressure plate to a diaphragm style pressure plate you should also remove the clutch pedal over center spring, if so equipped. Failure to remove the over center spring could result in the spring holding the clutch pedal down during normal operation. The over center spring will also tend to hold the pedal down while performing the bleeding operation, until the system is bled enough to return the pedal. An over center spring is not recommended for use with a diaphragm-style pressure plate, and the hydraulic system is not compatible with some three-finger style clutches. We strongly recommend a diaphragm-style pressure plate.

1. Install the push rod and pedal mounting lug on the master cylinder.
2. Assemble 5/16-18" x 1-1/4" bolt with (1) lock washer and (1) flat washer through rod end on master cylinder pushrod. Install to pedal mounting lug finger tight. See Figs. 4-1.
3. Make sure the pedal is against the upper stop (top of travel) and the push rod is perpendicular to the firewall to mark the clutch pedal for the location to drill the 5/16 hole for the mounting lug. Drill a 5/16 hole (centered front to back) in the clutch pedal to attach the mounting lug.
4. Attach mounting lug to clutch pedal using the hardware provided. Torque bolt to 13 ft.-lbs.
5. Adjust rod end position to achieve proper pedal height with master cylinder pushrod **EXTENDED ALL THE WAY OUT**. If the master cylinder is not fully extended when the pedal is at rest, the master cylinder can be difficult to bleed **and can overextend the CSC and cause it to fail**. Make sure the pushrod travels in and out of the master cylinder in a straight line and does not contact the firewall or mount block at any point during its travel. The master cylinder will not tolerate a side load and will wear out very quickly if the pushrod is going in at an angle greater than 6 degrees. **Make sure the pushrod is straight in line with the master cylinder!**
6. When the desired pedal height is achieved, tighten locknuts on pushrod.
7. Tighten clutch pedal rod end mounting bolt to 13 ft.-lbs.

DO NOT depress the pedal any more than necessary before fluid is added to the system.



FLUID RESERVOIR MOUNTING

1. Remove the studs or nuts on the left hand (driver) side of the brake master cylinder.
2. Place reservoir bracket over the two holes or studs in the brake master cylinder, replace the original studs or nuts and tighten completely. Alternatively, the reservoir may be attached directly to firewall or cabin sidewall.
3. Assemble reservoir to the bracket using hardware supplied (part # CAA-PACK A).

HYDRAULIC LOW PRESSURE HOSE MOUNTING

1. Run the rubber supply hose from the bottom of the reservoir nipple to the barb fitting in the clutch master cylinder and determine the exact length for the supply hose. The hose should be neither tight nor excessively loose and should clear all moving steering gear and exhaust components. Take care to prevent foreign debris from entering hose.
2. Cut the line to desired length, ensure that no foreign matter is in the hose. Then, loosely assemble hose clamps.
3. Install hose to the master cylinder, then to the reservoir. When installing hose to the reservoir, hold the top of the reservoir to prevent overloading and damaging the mounting ears.

HYDRAULIC HIGH PRESSURE HOSE MOUNTING

1. After bolting the transmission/bellhousing unit to the engine, attach the remaining end of the braided steel line to the clutch master cylinder and tighten. Use caution not to over tighten and break the fitting.
2. Final tighten all transmission mounting bolts (4 pcs).
3. Inspect the supply line inside bellhousing and confirm the hoses have ample clearance to the rotating clutch plate. It is extremely important that the hydraulic clutch hose **DOES NOT** come into contact with the clutch plate, as serious damage could result.

SYSTEM SPECIFICATIONS

Master cylinder: Bore = 0.750"
Stroke = 1.400"

CSC: Stroke = 0.910" total
available travel

CONTACT INFORMATION

SILVER SPORT TRANSMISSIONS
2250 STOCK CREEK BOULEVARD
ROCKFORD, TENNESSEE 37853-3043

Phone: (865) 609-8187
Toll Free: (888) 609-0094
Fax: (865) 609-8287

WWW.SHIFTSST.COM

SILVER SPORT TRANSMISSIONS IS DEDICATED TO YOUR SATISFACTION AND ENJOYMENT OF THIS PRODUCT. PLEASE SEND US PICTURES OF YOUR CAR ALONG WITH A TESTIMONIAL OF HOW YOU RATE THIS PRODUCT. WE WILL BE POSTING MANY CUSTOMER FEEDBACK LETTERS AND PICTURES ON OUR WEBSITE AND BROCHURES.

**ENJOY YOUR SILVER SPORT
TRANSMISSION SYSTEM!**